



Code of Practice:

**Raised timber deck
structures on new homes
- desired service life 60 years**

This Code of Practice has been produced by the Timber Decking Association to meet the quality and performance requirements expected by NHBC and other organisations committed to improving home building standards.

Code of Practice: TDA/RD 08/01

Raised timber deck structures on new homes -
desired service life 60 years

1st edition November 2008

© Timber Decking Association

The information contained in this document has been given in good faith. Every effort has been made to ensure the guidance given is accurate. The Timber Decking Association cannot accept any liability for loss or damage arising from the information contained herein or from any designer or contractor not complying with this guidance.

© Timber Decking Association Ltd (TDA) All rights reserved. No part of this document may be photocopied, scanned, reported or transmitted in any form without the prior permission of the TDA.

The TDA is an independent technical and advisory organisation founded in 1998 to establish and promote the materials, design and installation practices required to create high performance decks, boardwalks and associated landscape structures in wood.

The TDA operates DeckMark™ - a quality assurance and performance scheme for materials and contractors.



A list of approved products and contractors is available on request.

© Photographs - Acknowledgments

Page 5: Five Degree Piers

Page 9, Fig 8a: Hoppings Softwood Products; Fig 8b: Richard Burbidge; Fig 8c: Cheshire Mouldings

Introduction

Timber has a long history of use as a structural material. Unlike man-made materials it is a sustainable construction material with widely recognised environmental credentials. Increasingly, designers are turning to timber as the “green” building and engineering material of choice. The use of wood for external structures like decks, boardwalks and bridges has grown significantly in recent years. Where such structures are intended to be permanent, material selection, design, installation good practice and maintenance are key factors in ensuring fitness for purpose and long service life.

House builders are increasingly choosing to include timber decks on new properties to add customer appeal. On sloping land, raised decks are a practical solution to providing external leisure space where a traditional patio or garden is not possible.

Timber decks can be designed to meet a variety of service life requirements. For quality installations, 15 years is considered to be the minimum standard by the Timber Decking Association (TDA). Longer service lives, typically 30 and 60 years are also readily achievable. This Code of Practice (CP) has been developed to assist homebuilders meet the quality and performance requirements expected by NHBC and other organisations concerned with improving standards.

Leading designers, manufacturers and the Wood Protection Association have been consulted in the recommendations contained in this CP. References have also been drawn from the Building Research Establishment (BRE), TRADA and British and European Standards where relevant.

Those responsible for commissioning raised domestic decks should only use designers and installers of assessed capability with the experience and expertise required to carry out the work.

Definition of a raised deck

For the purposes of this CP, a “raised deck” is defined as a timber structure:

- a) having any part of its deck platform more than 60 cms from the ground;
- b) that is attached to a new residential property, no higher than the first storey level;
- c) that was included on the original design of the property and which is;
- d) installed prior to the issue of a new home completion certificate.

Any design having a deck platform under 60 cms in height is regarded by the TDA as garden or low level “decking”. Because of the lateral and vertical forces that a raised deck may be exposed to during its service life they are a lot more complex to build. The safety of those using the deck is the principal structural consideration.

Scope of this Code of Practice (CP)

This CP applies to raised decks for which a desired service life of 60 years is required. It includes guidance on:

- Timber selection
- Timber treatments
- Column specification and foundations
- Beam size and fixing
- Ledger board and fixing
- Joist size and fixing
- Deck board specification and fixing
- Parapet design and fixing
- Stairs
- Aftercare and maintenance
- Relevant Standards and References

Note:

- a) Residential decks on which hot tubs or other excessively heavy loads are to be placed are beyond the scope of this CP.
- b) Raised decks should not be used or occupied until final inspection and approval has been given by the new home insurance provider or building control officer.
- c) All dimensions quoted in this CP are target sizes unless otherwise stated.

Raised deck - general arrangement

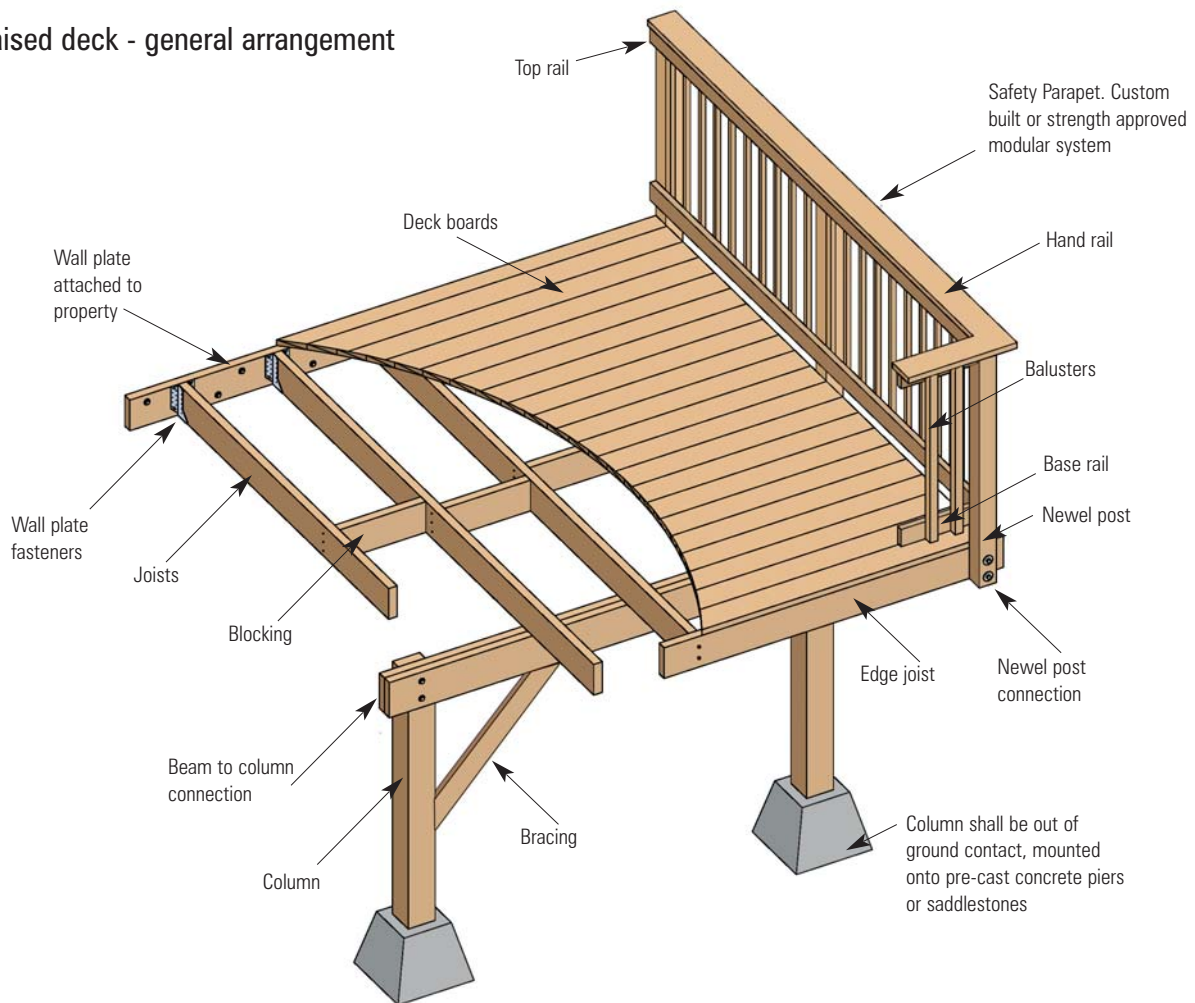

Load bearing assumptions

The guidance in this document provides for a uniformly distributed load of 3.0 kN/m² and concentrated load of 1.4 kN for the main deck platform and its support. The TDA recommends that this is the minimum standard that should be used for a raised timber deck on a residential property.

Parapets, whether a modular system or custom-built, must be capable of withstanding a horizontal, uniformly distributed load of 0.74 kN per metre and a single point load to the infill of 0.50 kN. Refer to Section 3.10: Parapet design & construction for details.

Metal fixings

All metal fixings shall be made from corrosion resistant materials such as stainless steel (Grade 316 minimum), silicone bronze, hot dipped galvanised (BS 7371-6) or other high performance coated steel. The suitability of a metal fixing for the type of timber being used should be verified by the manufacturer prior to use. The same type of metal should be used for fixings and connectors on the same assembly to prevent galvanic corrosion.

Electroplated, brass and standard ferrous metals should not be used because of their potential to corrode when used for exterior applications. Aluminium should not be used in direct contact with treated wood.

Consult TDA Technical Bulletin 08: Metal Fixings for detailed guidance.

Section 1. Timber selection

Whilst good design and installation practice have an important bearing on the long-term performance of a raised deck the first step to achieving a desired service life of 60 years is timber selection. Such an extended service life can only be satisfied by specifying timber that:

- a) has appropriate natural durability or
- b) has been made suitably durable by an appropriate wood protection process.

Table 1 lists those softwoods and hardwoods considered most suitable for structural use in extended service raised decks.

Designers and builders should only use timber from certificated, legal and sustainable sources. Components manufactured in accordance with the DeckMark™ quality assurance scheme provide independent confirmation of quality and fitness for purpose.

All timber for outdoor applications must have a moisture content below 20% at the time of installation to minimise the potential for movement – see note 1.4.

Table 1: Timbers suitable for decks requiring a 60 year service life

Softwoods (see note 1.1)	Hardwoods (see note 1.2)
British Pine/European Redwood	Balau (yellow)
Corsican Pine	Iroko
Radiata Pine	Jarrah
Southern Pine	Karri
Douglas Fir – British & North American	European Oak
Larch	Opepe
	Teak

1.1 Notes about softwoods

Components made from softwood must be given adequate durability by an industrial wood preservation process in accordance with Wood Protection Association specifications and BS EN standards. Modified wood processes also produce timber suitable for external applications. Guidance on wood protection is given in section 2.0 of this document.

European Whitewood (spruce) is not considered suitable for a structural use in decks or boardwalks where a service life in excess of 15 years is required.

1.2 Notes about hardwoods:

Hardwoods with well-documented performance properties and a history of external structural use are set out in the timber design code BS 5268: 2. Those considered to be the most suitable for decks are set out in Table 1. All the species listed in Table 1 have a BS EN 350-2 class 1 (very durable) or class 2 (durable) rating and are capable of a long service life for structures such as decks, boardwalks and bridges.

There are also a number of other hardwoods, from certificated sources, that are now commercially available for deck construction. Examples include: Cumaru, Garapa, Ipe, Keruing, Kempas, Massaranduba and Tatajuba. The major suppliers, such as the manufacturing members of the TDA, may be able to provide technical information about their performance properties if required.

Only hardwoods from which all sapwood has been excluded should be used.

1.3 Timber strength class

Timber used for structural purposes must be strong enough to support the loads placed upon it. This is a safety critical requirement of UK Building Regulations. Every structural component in a raised deck should be made from strength-graded timber. Graded timber is grouped into a number of Strength Classes as defined in BS EN 338: Structural Timber. The strength classes for softwoods are prefixed with the letter C and hardwoods with the letter D. In the softwood strength classes, C16 is the minimum standard for raised deck construction, provided its span and load capabilities are not exceeded. C24 is the strength class more typically recommended because it allows longer spans, slightly smaller component sections and may have a better visual appearance. D30 is the minimum strength class for hardwoods.

The same species and strength class must be used for all the support structure elements of the deck.

Graded timber that does not carry the “grade stamp” of an approved accreditation body should not be used. Where, for aesthetic reasons, a grade stamp is not applied to the timber then the strength class must be capable of identification by other means such as supplier documentation.

1.4 Installation moisture content

The moisture content of wood is directly related to the humidity and temperature of the surrounding air. The equilibrium moisture content (EMC) occurs when the wood has reached an equilibrium with its environment and is no longer gaining or losing moisture. In the UK, EMC ranges from around 19% in winter to 13% in summer. To minimise the potential for defects such as cupping, warping and cracking, timber components should have a moisture content close to the prevailing EMC at the time of its installation. As a minimum standard, the moisture content of timber components shall be under 20% at time of installation.

Deck construction components delivered to site shall be given adequate, ventilated, weather protection until required for installation.

Section 2.0 Timber protection

For domestic decks, two methods of providing softwood with adequate durability to satisfy a 60 year service life are considered in this document. They are:

- a) high pressure impregnation with wood preservative (see 2.1) and,
- b) wood modification (see 2.2)

2.1 High pressure impregnation with wood preservative

BS 8417 sets out penetration/retention requirements for different timber types, end uses and service life requirements. This Standard is used as the basis for the treatment specifications set out on this page in conjunction with BS EN335-1, which classifies end use applications, Wood Protection Association (WPA) commodity specifications and major preservative suppliers. BS EN599-1 defines the test criteria that supports the long-term performance of components treated with the preservatives defined in BS 8417.

It is the responsibility of the treater to use the appropriate schedule to achieve the values and quality required in the specifications set out in this CP. As such, designers and builders are recommended to use treaters accredited to the WPA.

Treatment specification for a 60 year desired service life

a) Columns (support posts) installed out of ground contact:

Columns shall be treated in accordance with BS 8147: 30 years extended life specification for BS EN335-1 Use Class 4: direct ground or freshwater applications. Sapwood penetration shall be in accordance with EN351-1, penetration class P8 to an acceptable quality level (AQL) of 10% (see Note:e below). In addition, the preservative retention shall be derived from 10 years ground contact field test data.

For glue-laminated posts, untreated zones not exceeding 10% of the sapwood for which penetration would be expected in an individual component of the lamination may be ignored in the assessment of penetration.

b) Stair stringers:

Stringers close to ground contact shall be treated as columns as 2.1(a). All other stair parts should use the specification set out in 2.1(c) below.

c) Beams, wall plates, joists, deck boards and parapets/balustrades:

Treatment shall be in accordance with BS 8417 30 year extended specification for BS EN335-1 Use Class 3 (uncoated applications) or better. In this specification, sapwood penetration shall be in accordance with EN351-1, P8 rating to an acceptable quality level of 10%.

Notes about high pressure wood preservation

- a) Components must be machined to their final dimensions and have a moisture content prior to treatment not exceeding 20%.
- b) During installation, surfaces exposed by cross cutting, notching or boring shall be given two liberal brush coats of a suitable end grain preservative. Contact the TDA, WPA or major preservative manufacturers for recommendations.
- c) If it is necessary to cross cut columns to size then the cut end should always be at the top and never placed close to or in contact with the ground or concrete foundation.

- d) Machining or regularising treated components is prohibited unless they are to be re-treated by the timber supplier. Deck platforms should always be designed to avoid the need to cut a deck board along its length.
- e) Acceptable quality level (AQL): This is the number of components in a treatment charge which can be below the required penetration level before the entire charge is deemed non compliant with the specification. e.g 10% for most common pines but 25% for more naturally durable species like Douglas Fir.

2.2 Modified wood

Modified wood is a term used to describe permeable softwoods that have been modified chemically, biologically or by a physical agent such as heat to provide enhanced performance properties - for example acetylated wood.

Because "modified wood" is still a relatively new construction material it is not, as yet, covered by British or European Standards. However, BRE Digest DG504 sets out the suitability of modified wood for construction purposes and decking is identified as a potential application.

TRADA has carried out an independent evaluation of Accoya™ (acetylated radiata pine) for deck structures for which 60 years service life is desired.

Section 3.0: Principles of raised deck design and good practice

The durability of the structure and its ability to achieve the service life required depends not only on the correct selection of materials but also on design detailing and installation good practices to prevent moisture retention and facilitate good ventilation and drying. Section 3.0 of this CP covers the basic principles for a deck where the desired service life is 60 years. Guidance on deck structures where 15 or 30 years service life is required is available from the TDA.

3.1 Columns

Raised deck support columns are usually square in section but round poles may be used if appropriate to the design. Traditionally columns are solid wood but increasingly designers are turning to laminated columns.

Laminated columns comprise multiple sections of strength-graded timber bonded together with glue or mechanically. Laminated columns are more dimensionally stable than solid ones of equivalent size and are less likely to develop surface defects. This gives them high aesthetic appeal for raised decks where the columns are visible.

The recommended target size of support columns is 150 x 150 mm. The actual finished size shall be no less than 140 mm x 140 mm.

The sole purpose of a column is to support the entire structure. It is recommended that support columns are not carried through the deck to serve as newel posts for a parapet. Parapets for raised decks should always be designed as separate features – see section 3.10 for details.

3.2 Column footings

Columns embedded in the ground are suitable for decks with a service life of up to 30 years. To deliver a 60 year service life, timber columns shall be installed clear of the ground on a concrete footing, pier or saddlestone – see Figure 1.

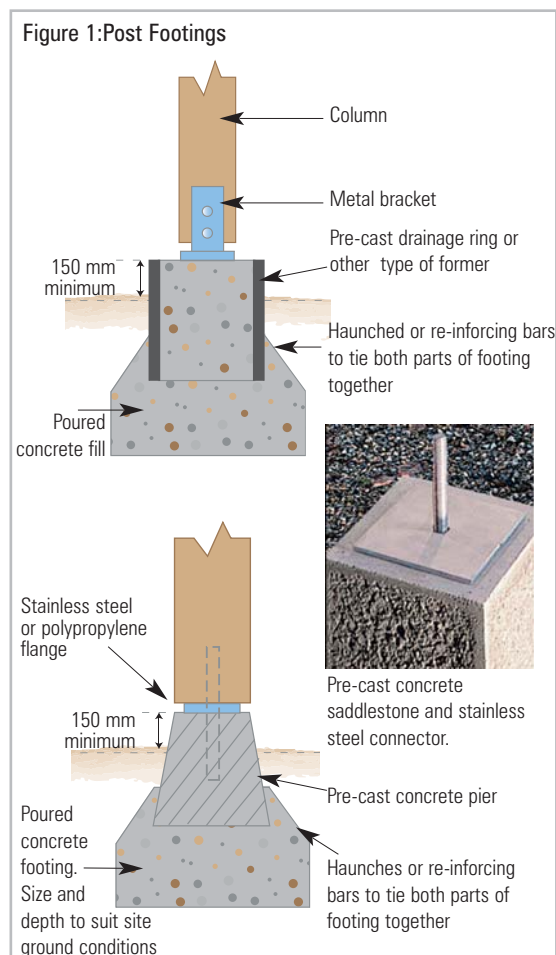

3.3 Column spacing

The correct spacing of support columns is determined by a combination of:

- the area of the deck to be supported
- beam position and frequency
- the dimension of the beam
- the nature of the ground and the 3 kN/m² loading of the deck.

3.4 Beam size

The main support beams may be made from either solid timber or from double sections of the same size and strength component mechanically joined together.

The minimum target size for a single solid beam is 75 mm x 195 mm (actual size 69 x 187 mm).

The minimum target size for each element in a double beam assembly is 175 mm x 47 mm (actual size 170 x 44 mm).

Beam spans for various recommended sizes and strength classes are set out in Table 2. Beams can be extended beyond a column centreline by up to 30% of its clear span.

Table 2: Double member beams – maximum clear spans between columns

Actual size mm	C16	C22	C24	D30
170 x 44	1.5	1.55	1.65	1.7
195 x 44	1.8	1.95	2.1	2.2
220 x 44	2.4	2.5	2.7	2.8
245 x 44	3.0	2.15	3.3	3.4

Single member beam - maximum clear spans between columns

Actual size mm	C16	C22	C24	D30
187 x 69	1.8	2.0	2.1	2.2

Note: The above spans are indicative only and assume stable ground conditions.

All raised deck designs shall be verified by a structural engineer or suitably qualified designer prior to construction.

3.5 Beam to column connection

Beams are attached to support columns by means of notching the column and using 12 mm through bolts at 100 mm centres - see Figure 2. All through bolts shall have washers at the bolt head and nut. These washers shall be of a size that is the equivalent of 3 times the diameter of the bolt.

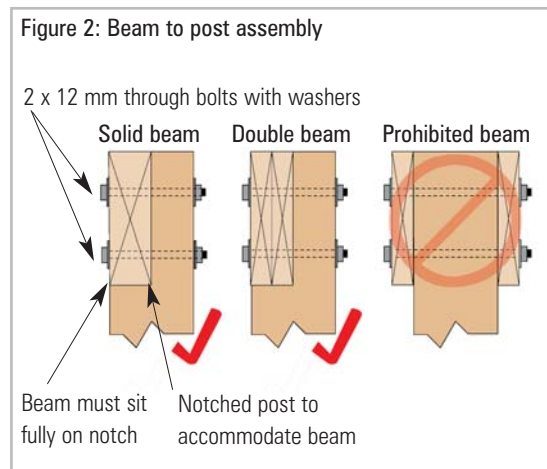

3.6 Wall plate

The deck is secured to the wall of the property by means of a horizontal joist or beam known as a wall plate or ledger board. This supports one end of the deck joists. The other end is supported by the column and beam assembly.

Wall plates shall be equal to or greater than the size of the joist that is to be used.

The wall plate shall be attached to the house wall using masonry anchor bolts or chemically secured bolts. The wall needs to be smooth, structurally sound and capable of withstanding the lateral and pull out loads that will be placed on it by the deck.

A gap of no less than 10 mm shall be left between the wall plate and the wall to allow any rainwater running down the wall to drain away freely. Wall plate fixing details are shown in Figure 3.

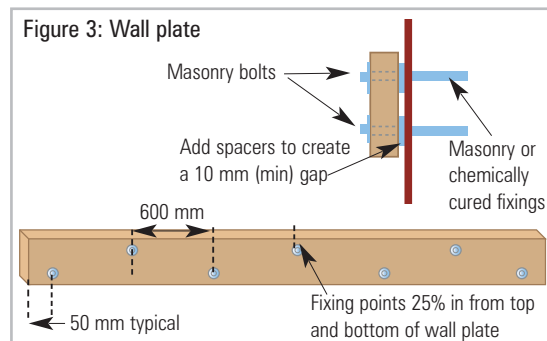

Note: Wall plates on timber frame properties

On timber frame properties decks should not be fixed to the outer skin of the property unless the deck wall plate/ ledger board fixing point has been designed to be an integral part of the properties construction.

3.7 Joists

The recommended processed joist size is 170 mm x 44 mm or larger, installed at 300 mm to 600 mm centres depending upon the size and grade of deck board being used – see Table 4 in section 3.9 for details. As a general rule, it is good practice to increase the frequency of the support joists rather than the thickness of the deck board.

The table below gives details of the maximum spans for the most popular joist sizes.

It is preferable to use processed joists with eased edges to assist water shedding.

Table 3: Maximum joist clear span distance at 400 mm centres

Actual size	C16	C22	C24	D30
170 x 45 mm	2.7m	2.8m	3.0m	3.1m
195 x 45 mm	3.0m	3.1m	3.3m	3.4m

Joists may be mounted on top of the wall plate or the outer beam, but not both. One end shall be face fixed to prevent turning – see Figures 4 to 5.

Joists may be cantilevered over a beam by up to 30% of their permissible clear span.

3.8 Blocking and bracing

3.8.1 Blocking, (also known as strutting) should be installed between joists to further reinforce the strength of the structure and prevent joists from moving in service. As a minimum requirement, all joists with a span of more than 2.5 m shall be blocked at mid-span – see Figure 6a. Deeper joists will need blocking at more frequent intervals.

Joists adjacent to other load-bearing components such as a newel post fixing point should always be blocked - see Figure 9 on page 11.

Figure 6a: Blocking joists

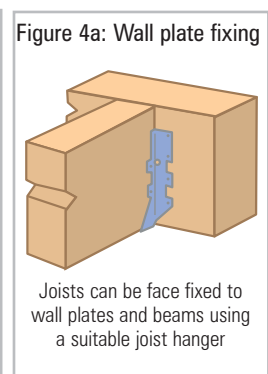
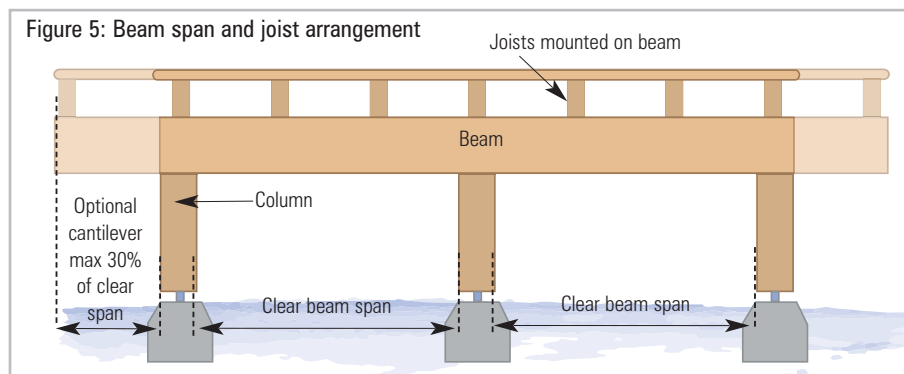
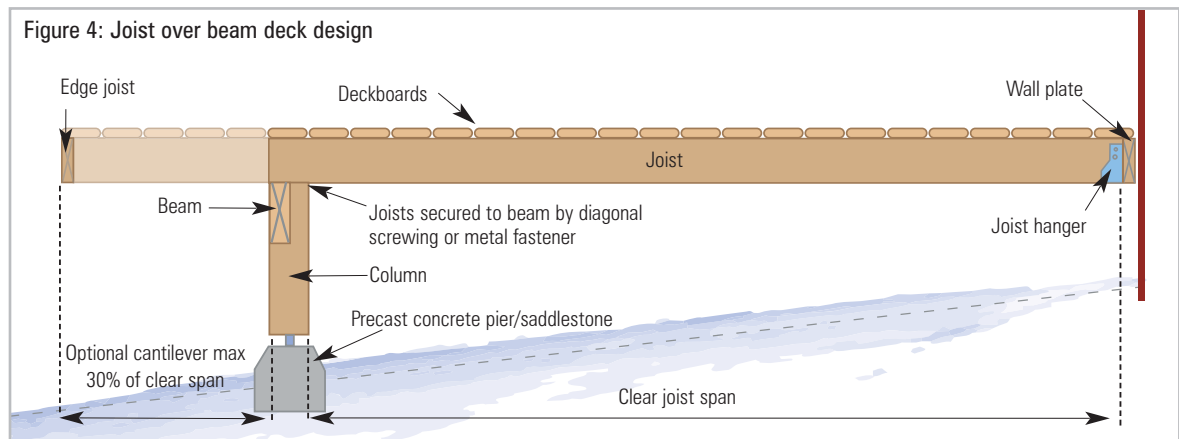
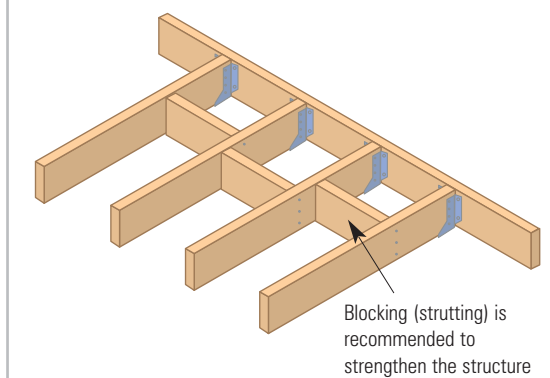

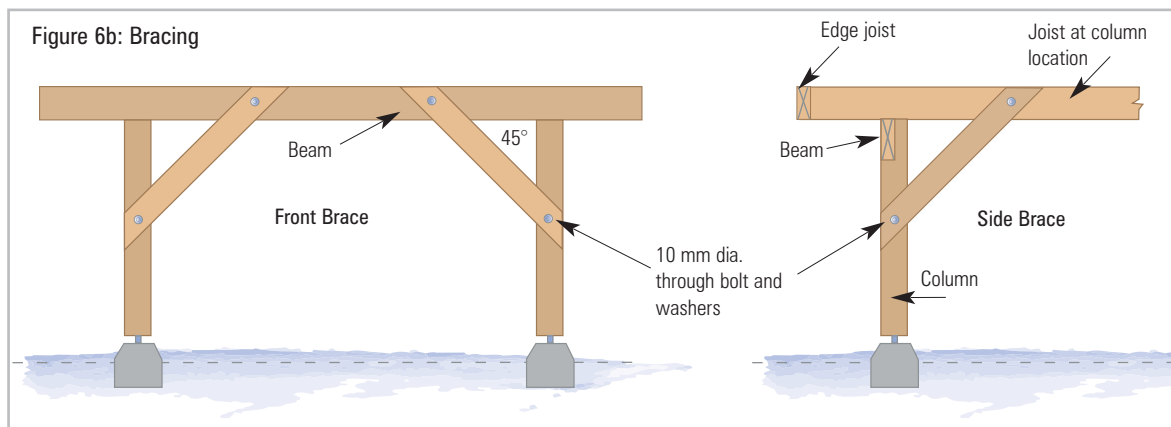

3.8.2 Diagonal bracing provides lateral stability to tall columns and should be used on all decks that exceed 1.5 m in height, whether they are free standing or attached to a property – see Figure 6b.

3.9 Deck boards

The decked surface is the most visible part of a deck and provides the structural integrity for the load bearing capability of the platform. It is also important that boards are of good visual appearance. As a consequence the specification of unsorted or good 5th quality boards is recommended as the minimum standard for softwood and that they are visually checked for quality before installation. Hardwood deck boards should be visually checked prior to installation. Any sections in which sloping grain affects the surface appearance of the board should be rejected.

Deck boards come in a range of finished sizes and styles from around 90 mm in width upwards. To minimise the effect of changes in deck board moisture content and improve drainage and underfoot grip, the maximum actual width shall not exceed 145 mm.

Table 4 details the maximum span capabilities of typically available deck boards for a platform with a design load of 3.0 kN/m². Where diagonally boarded platforms are concerned, joist centres will need to be closer to meet the span distances detailed in Table 4. Hardwood boards should be used in preference to softwood versions where a board under 28 mm in thickness is required.

A 10% tolerance has been built in to these recommendations to allow for grooved deck boards on the assumption that the grooves are no deeper than 5 mm and that the grooves do not cover more than 50% of the machined surface.

Table 4: Deck board maximum support centres for a 3.0 kN/m² platform

Actual size mm	C16	C22	C24	D30 (OakTH1)
95 x 22	-	-	-	300
95 x 34	450	500	550	550
120 x 22	-	-	-	350
120 x 27	400	425	450	450
120 x 34	500	550	600	600
145 x 22	-	-	-	400
145 x 27	400	425	450	450
145 x 34	500	550	600	600

Deck board style - plain, ribbed or grooved is a matter of aesthetics – surface drainage is the most important factor in how they are laid and perform long term. Complex patterns should be avoided.

3.9.1 Surface drainage

All boards shall have radiused or chamfered outer edges to assist water shedding and minimise the likelihood of edges splintering if subject to impact.

To further assist drainage, ventilation of the structure and accommodate any seasonal movement of the wood, a gap – 5 mm minimum, 8 mm maximum - shall be left between each board. This gap shall be consistent in size across the entire surface. A minimum gap of 5 mm should be left where a board abuts a balustrade posts.

Boards that are designed to help channel surface water should ideally be laid with the grooves running on a line of positive fall, preferably across the short dimension of the deck. Plain boards may be laid in any direction.

3.9.2 Board fixing

Ideally, only full lengths of boards should be used. Where it is necessary to abut two boards then this junction shall be over a joist and an additional batten or section of joist shall be used to support the join (see Figure 7a for details). A small gap, maximum 2 mm should be left between abutting boards to allow for any lateral movement of the board throughout the seasons.

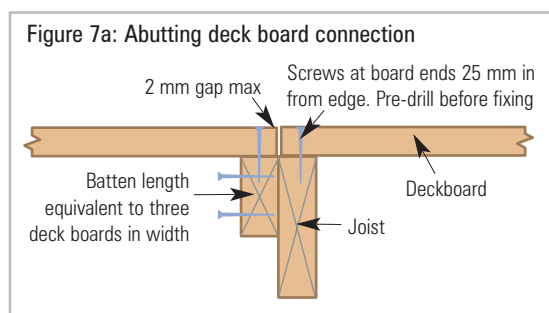

Nails and proprietary clips are not considered appropriate for installing boards on decks where the service life requirement is 60 years. Screws should be used because they are more secure; are unlikely to lift during service; can be removed to permit maintenance if required; are less likely to be damaged during installation and dents in the surface caused by hammers or high pressure guns are avoided.

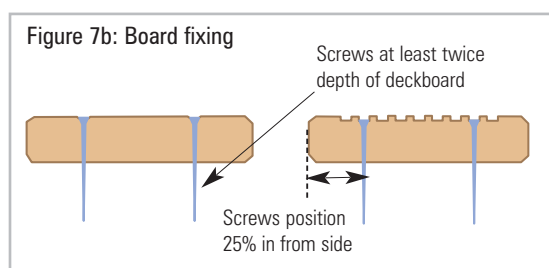

Screws shall be at least twice the depth of the board size. All joist crossing points shall be secured by two screws positioned at the quarter points of the board i.e. 25% in from the side - see Figure 7b.

Screw heads should be countersunk level with the surface of the board or just slightly below the surface if the board has a moisture content higher than the equilibrium moisture content at the site – see section 1.4.

On grooved boards the fixing point should always be at the bottom of a groove, flush with the surface of the wood.

Fixing points at board ends shall be no closer than 25 mm to the board end and should always be predrilled to prevent splitting.

For hardwoods, every fixing point shall be pre drilled and countersunk level with the surface. The drill hole should be 2 mm larger than the diameter of the screw shank being used to allow for any movement that may occur as the timber adjusts its moisture content with the seasons.

3.10 Parapets and balustrades

Building regulations require that decks more than 600 mm from the ground be fitted with a safety parapet or balustrade system. These shall be at least 1100 mm high and must be capable of withstanding a horizontal load of 0.74 kN per metre and a single concentrated load of 0.50 kN. In addition the parapet design shall discourage climbing and the spaces between individual elements shall measure less than 100 mm. Parapet newel posts must be completely separate to the principal deck platform support columns.

To meet the above specification raised deck parapets are mostly custom made on-site and guidance can be found on the next page of this CP. Modular balustrade systems may be used if they have been independently tested in accordance with BS 6180 and 6399:1 for high-level applications and have quality and performance certification under schemes such as DeckMark operated by the TDA and Q –Mark by TRADA. Modular systems must always be installed in accordance with the manufacturers instructions.



Figure 8a: Strength assessed raised level parapet system.
Figures 8b and 8c: Contemporary design modular systems for raised decks

3.11 Custom built parapets

For custom-built parapets only timber from the C24 strength class (or hardwood equivalent) should be used unless all the components are part of a strength assessed parapet system.

The minimum actual size for a raised deck newel post shall be 90 mm. These shall be spaced at no more than 1500 mm centres unless the component is part of a system that has been strength assessed for use at greater centres.

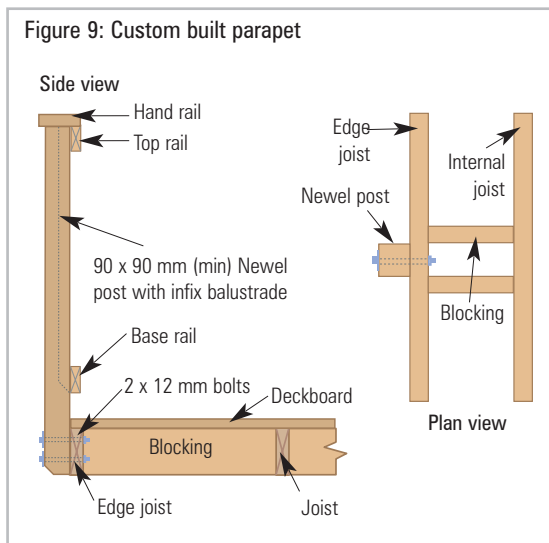

Figure 9 shows a typical custom-built parapet specification. It should be noted that newel posts should be fixed directly to the edge joists and the front "header" joist. All joists must be at least 45 mm wide and suitably reinforced. Typically, newel posts are secured using two 12mm through bolts with washers at both the bolt head and nut. These washers shall be three times the diameter of the bolt in size.

Deck support columns must never be carried through the deck to serve as a newel post on raised decks. Comprehensive design details can be found in TDA Technical Bulletin 04: Parapet Design & Construction.

All newel posts and vertical members should be capped to prevent end grain exposure to moisture.

3.12 Access stairs

Where raised decks have stairways, the installation shall be inline with Part M of building regulations. Additionally, the following guidelines are recommended.

Stairs for decks up to 2.5 m in height can be accommodated in a single run. There should be no more than 14 stair treads in a single run. For decks higher than this or where there is a desire to make stairs a less imposing feature then a half landing or change of direction should be incorporated.

For steps to be safe and comfortable the riser height and step (going) must maintain a consistent relationship. The minimum step going is 250 mm. For outdoor stairways, risers are normally left open - but any openings must be less than 100mm. It is good practice to only use solid stringers on raised decks. A typical stairway style is shown in Figure 10.

Stairs that are less than 1.22 m wide must have a handrail meeting the same requirements as the deck parapet (Section 3.10). Handrail newel posts must always be bolted to the stair stringer, never to stair treads.

Specialist advice is available from the TDA for properties that require a timber ramp for wheel chair access.

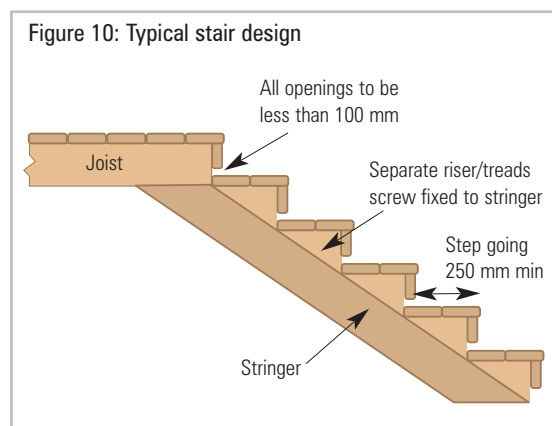

Section 4.0 Aftercare and maintenance

If the guidance on material selection, design and installation contained in this CP are followed then minimal housekeeping maintenance and cleaning will be required.

The principal structural timbers recommended do not require any further treatment or protective coating and can be allowed to bleach out and weather naturally. Timber decks and boardwalks that have weathered for 60 years and more have considerable character that many people find attractive. However, where there is a desire to maintain the colour and appearance of the newly installed deck, or to decorate with another colour, then clear water repellent sealers, oils or pigmented stains and paints may be used. Such products may be used at any time during the life of the deck. Surface preparation, application and maintenance shall be in accordance with the product manufacturers recommendations.

Components that are supplied prefinished with a factory applied decorative coating should be linked to an appropriate manufacturers maintenance and aftercare scheme.

During the weathering process small surface splits or checks are inevitable. They are caused as wood expands and contracts with the seasons and should not be regarded as defects. They do not have any effect on the structural integrity of a deck. If however major cracks and through splits do appear within the first few years following completion of the deck then the homebuilder should be contacted immediately to carry out a structural assessment.

Section 5.0 Specification verification

"We consider that a raised timber deck that is designed by a suitably qualified person in accordance with this Code of Practice using appropriate quality materials installed by a competent contractor will produce a structure of outstanding durability and stability capable of meeting a 60 year service life with minimum maintenance."

Timber Decking Association
January 2008

Section 6.0 Relevant standards and references

BS 5268-2: Structural use of Timber. Code of practice for permissible stress design, materials and workmanship.

BS 4978: Specification for visual strength grading of softwood.

BS EN 335:1 Use classes of wood and wood-based products against biological attack – Classification of Use classes.

BS EN 335:2 Use classes of wood and wood-based products against biological attack – Guide to the application of use classes to solid wood.

BS EN 350-1 Durability of wood and wood-based products – Natural durability of solid wood – Part 1: Guide to the principles of testing and classification of the natural durability of wood.

BS EN 350-2 Durability of wood and wood-based products – Natural durability of solid wood – Part 2: Guide to natural durability and treatability of selected wood species of importance in Europe.

BS EN 351-1 Durability of wood and wood-based products. Preservative-treated solid wood – Part 1: Classification of preservative penetration and retention.

BS EN 351-2 Durability of wood and wood-based products. Preservative-treated solid wood – Part 2: Guidance on sampling for the analysis of preservative-treated wood.

BS EN 460 Durability of wood and wood-based products Natural durability of solid wood: Guide to the durability requirements for wood to be used in hazard classes.

BS EN 599-1 Durability of wood and wood-based products - Performance of wood preservatives determined by biological tests Part 1: Specification according to use class.

BS 8417 Preservation of timber – Recommendations. Guidance for specifiers on the treatment of timber drawing on relevant sections of BS EN Standards.

BS 5756: Specification for visual strength grading of hardwood.

BS 6105: Specification for corrosion resistant stainless steel fasteners.

BS 6180: Barriers in and about buildings – Code of Practice

BS 6399-1: Loading for buildings. Code of Practice for dead and imposed loads.

BS 7359: Nomenclature of commercial timbers, including sources of supply.

References

BRE Digest DG503: External Timber Structures – preservation and durability

BRE Digest DG504: Modified Wood

TRADA – Timber Decking “The Professional’s Manual”

TDA – Technical bulletin 04: Parapet design & Construction

TDA – Technical bulletin 08 : Metal fixings

TFT – Information sheet: Strength Graded Timber – the basics

Wood Protection Association – Industrial wood preservation specification & practice

Part M. Building Regulations England and Wales: Access to buildings.



Timber Decking Association

5 Flemming Court
Castleford
West Yorkshire
WF10 5HW
01977 558147
www.tda.org.uk